



BRS



Since 1908

CONCASSEURS À MACHOIRES

Concasseurs à mâchoires à simple effet de robustesse exceptionnelle, ils peuvent être utilisés soit comme primaires que comme secondaires.

JAW CRUSHERS

Single toggle jaw crusher-exceptionally strong they can be used both for primary and secondary crushing.

FRANTOI A MASCELLE

Frantoi a mascelle a semplice ginocchiera di eccezionale robustezza, adatti sia ad impiego primario che secondario.



Legenda



1	MASCELLA FISSA	FIXED JAW	MÂCHOIRE FIXE
2	MASCELLA MOBILE	MOBILE JAW	MÂCHOIRE MOBILE
3	VOLANO	FLYWHEEL	VOLANTS
4	ALBERO ECCENTRICO	ECCENTRIC SHAFT	ARBRE ECCENTRIQUE
5	OSCILLATORE	JAW HOLDER	BALANCIER PORTE MÂCHOIRE MOBILE
6	SPessori DI REGOLAZIONE	ADJUSTING SHIM	COINS DE RÉGLAGE
7	MARTINETTO IDRAULICO	HYDRAULIC JACK	VERIN HYDRAULIQUE
8	MOLLA DI RICHIAMO	RETURN SPRING FOR JAW HOLDER	RESORT DE RETOUR
9	CUSCINI GINOCCHIERA	TOGGLE CUSHION	VOLET D'ARTICULATION À
10	GINOCCHIERA	TOGGLE	CONTACT ROULANT

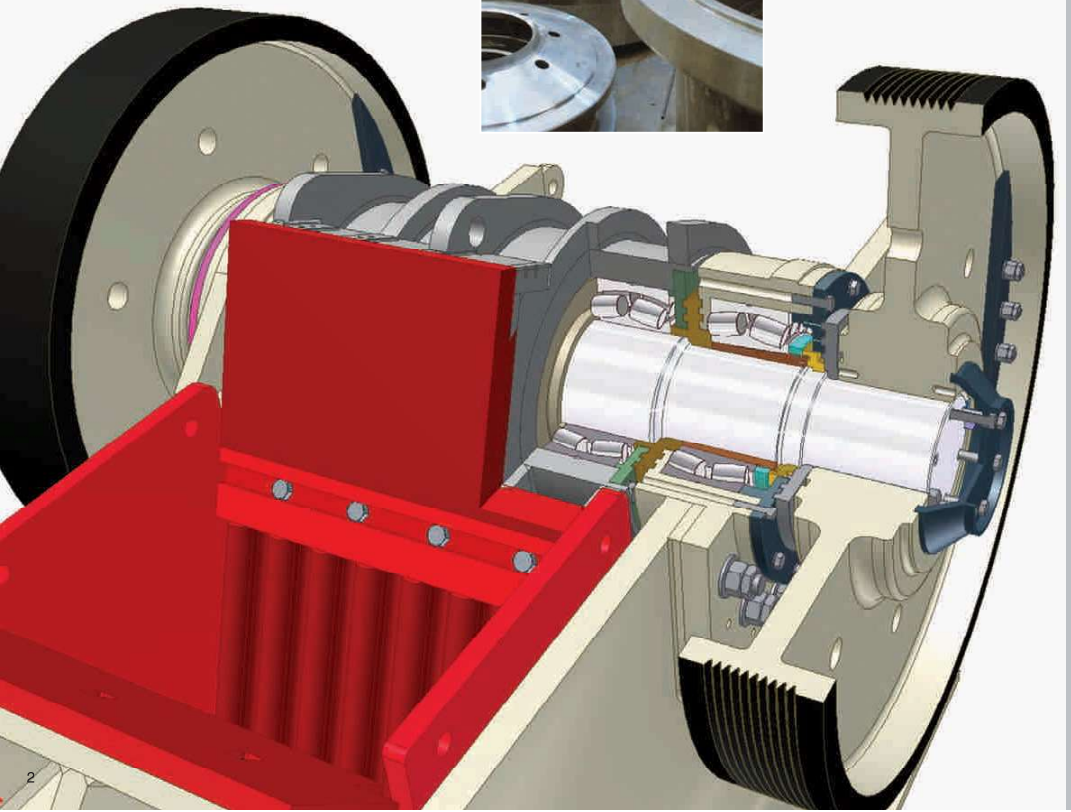
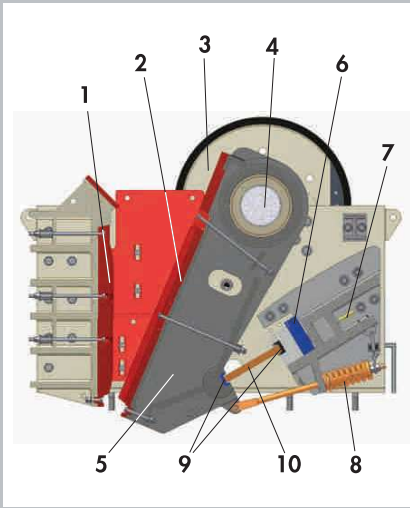



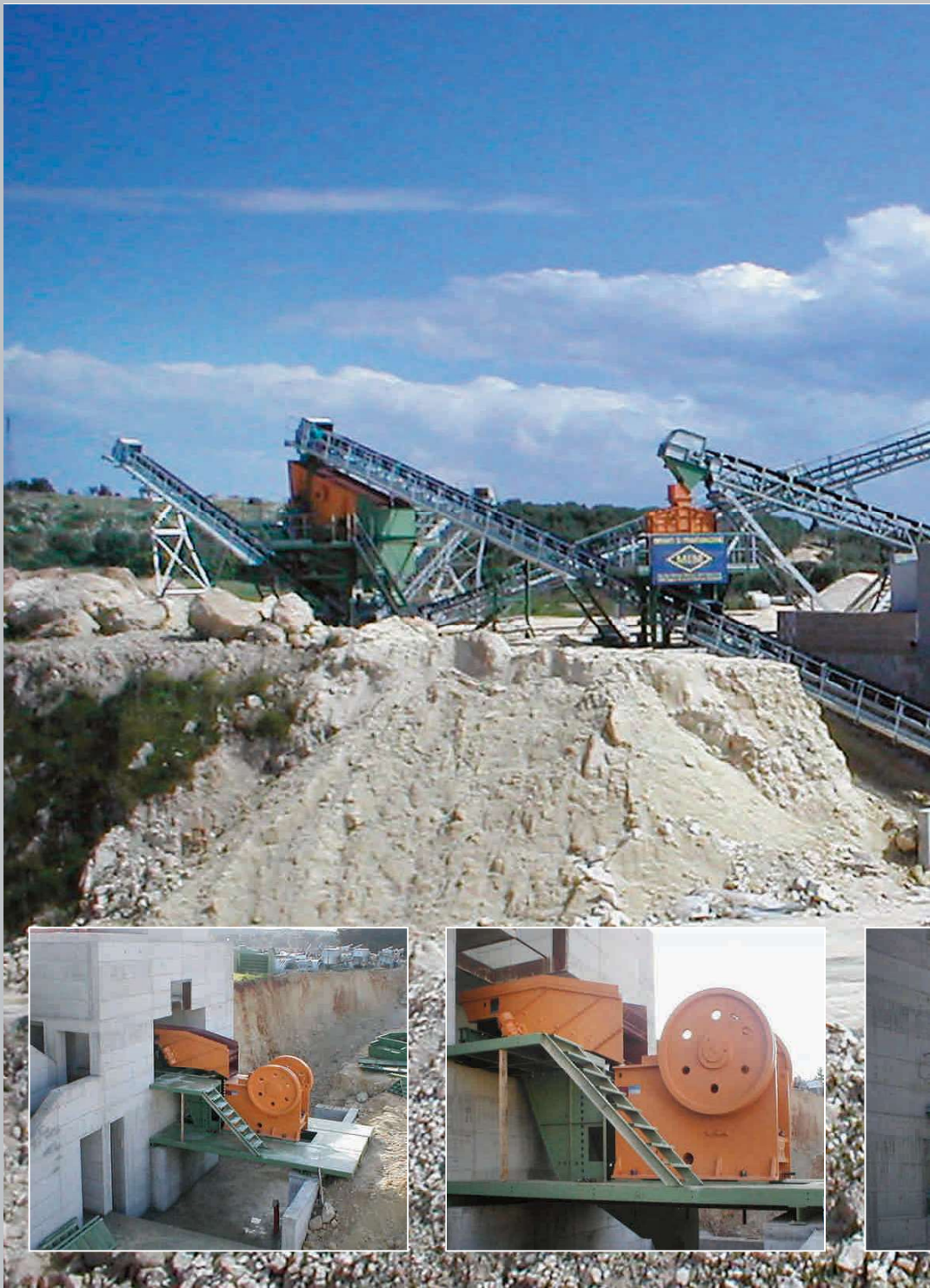







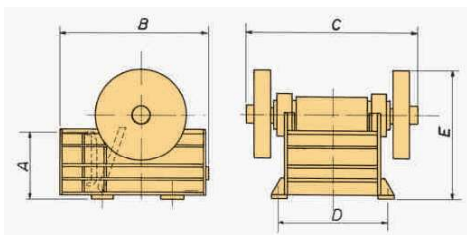

Modello Type/Modèle	A	B	C	D	E
BRS 60-40 [mm]	995	1.650	1.710	920	1.590
BRS 75-50 [mm]	1.118	2.070	1.915	1.050	1.845
BRS 90-65 [mm]	1.450	2.110	2.175	1.240	2.405
BRS 105-75 [mm]	1.940	2.700	2.470	1.550	2.805
BRS 120-90 [mm]	2.350	3.300	3.000	1.800	3.182
BRS 150-120 [mm]	2.850	4.590	3.340	2.150	3.553

Modello	Dimensione Bocca	Produzione	Potenza installata	Giri max. macchina	Peso macchina
Type	Upper mouth opening	Production	Installed power	Machine r.p.m. Max.	Machine weight
Modèle	Ouverture	Production	Puissance installée	Vitesse de rotation Max.	Poids machine
	[mm]	[T/h]	[kW]	[rpm]	[kg]
BRS 60-40	600 x 400	20 ÷ 50	30	275	6.500
BRS 75-50	750 x 500	50 ÷ 140	55	275	10.600
BRS 90-65	900 x 650	140 ÷ 220	75	250	15.300
BRS 105-75	1.050 x 750	180 ÷ 270	90	250	26.300
BRS 120-90	1.200 x 900	190 ÷ 310	110	200	50.000
BRS 150-120	1.500 x 1200	250 ÷ 650	160 ÷ 200	180	91.500

Le caratteristiche e le dimensioni non sono impegnative e la MEM si riserva di apportare modifiche e miglioramenti per ragioni commerciali e tecniche in qualsiasi momento e senza preavviso.

Features and dimensions are not engaging and MEM can make changes and improvements for commercial and technical reasons at any moment and without notice.

Les caractéristiques et dimensions ne sont pas obligantes et la MEM se réserve d'apporter modifications et améliorations pour raisons commerciales et techniques en quelconque moment et sans préavis.



MEM PROGETTA E COSTRUISCE LA PIÙ VASTA GAMMA DI MACCHINE
PER LA FRANTUMAZIONE DEGLI INERTI, REALIZZATE IN ITALIA

GESTIONE DI:

MATERA NV/SA - Z.I. DE SAUVENIERE, RUE DES PRAULES 3A - B-5030 GEMBOUX - BELGIUM
TEL +32 (0)81 62 75 20 - FAX +32(0)81 62 75 14 - parts@matera.be - www.matera.be