

# Mine dump truck BELAZ-755E of payload capacity 60 tonnes (66 short tons)

It's designed for transportation of rock mass in difficult mining and technical conditions of deep mines, at mineral deposit open pits on technological roads under various climatic operating conditions (at ambient temperature from -50 to +50 °C).



## Engine

Model	CUMMINS QSK 19-C
Four-cycle turbocharged direct diesel engine with in-line arrangement of cylinders.	
Rated power @ 2100 rpm, kW (hp)	560 (750)
Maximum torque @ 1300 rpm, N.m	3084
Number of cylinders	6
Cylinders displacement, l	18,9
Cylinder diameter, mm	159
Piston stroke, mm	159
Specific fuel consumption at rated power, g/kW hr	211
Air cleaning is performed by three-stage filter with dry-type elements.	
Engine exhaust expulsion is performed through body.	
Mixed-type lubrication system is designed with "wet" crankcase.	
Fluid cooling system with forced circulation is integrated with cooling system of hydromechanical transmission. Hydromechanical transmission oil cooling is performed by oil-to-water heat exchanger.	
Fluid preheating system.	
Electric starter starting system.	
Electric equipment system voltage, V	24

## Hydromechanical transmission

Hydromechanical transmission with complex one-stage four-wheeled torque converter with hydraulic clutch mode and automatic locking, four-shaft gearbox with friction clutches and electrohydraulic actuator of gear change control, automatic control and protection micro-based system, emergency gear change command control without automatic locking of torque converter.

Maximum dump truck travel speed, km/h	55	
Hydromechanical transmission 6+1 gearbox ratios:		
gears	forward	reverse
1	4,070	4,530
2	2,865	
3	2,045	
4	1,437	
5	1,011	
6	0,722	

## Suspension

Suspension is conventional for front and driving axles.	
Cylinders are pneumohydraulic (nitrogen and oil) with inbuilt hydraulic shock absorber. Two cylinders are on the front axle and two cylinders are on the rear axle.	
Cylinder piston stroke, mm	
- front	300
- rear	270

## Steering

Hydrostatic steering with steerable front wheels.	
Steering angle, degree	41
Turning radius, m	9
Overall turning diameter, m	20,5
The steering meets ISO 5010 requirements.	

## Brakes

Dump truck brake system meets ISO 3450 international safety requirements and is equipped with service, parking, auxiliary and emergency brake systems.	
<b>Service brake system</b> consists of front wheels dry-type disk brakes and rear wheels multiple-disk oil-cooled brakes. Actuator is hydraulic and separate for front and rear wheels.	
<b>Parking brake system</b> is permanently closed shoe brake gear on final drive driving shaft with spring actuator and hydraulic control.	
<b>Auxiliary brake system</b> uses rear wheels multiple-disk oil-cooled brakes with hydraulic actuator. Braking by service brakes with the view of deceleration is effected by separate foot pedal.	
<b>Emergency brake system</b> uses parking brake and operable circuit of service brakes.	

## Hydraulic drive

Hydraulic system is combined for body dumping gear, steering and brakes actuator. The system is equipped with gear-type oil pumps and two-stage telescopic body lifting cylinders with one stage of double action.	
Body lifting time, s	15
Body lowering time, s	14
Maximum pressure in hydraulic system, MPa	17
Maximum pump delivery @ 2100 rpm, dm <sup>3</sup> /min	342
Filtration degree, mcm	10

## Body

Welded bucket-type body with FOPS safety system, protective canopy, engine exhaust heating, device for mechanical fixing in raised position and rock-ejectors.

Body capacity, m<sup>3</sup>:

struck	heaped 2:1
28	37,3
51,5	57,9



## Frame

Frame is welded of high-strength low-alloy steel with application of cast elements at the maximum loading points and equipped with box-section variable-height side-members interconnected by cross-members.

## Driving axle

Mechanical driving axle is equipped with single-stage bevel final drive, bevel differential with four pinions and planetary hub drives with spur pinions.

Ratios:

final drive	2,73
hub drive	7,62
driving axle total	20,8

## Driveline

Driveline consists of two open-type cardan shafts with joints on needle bearings that join hydromechanical transmission to engine and driving axle. Flexible coupling is mounted between front cardan shaft and engine. Front cardan shaft is equipped with protective guard.

## Cab

Two-man two-door cab is equipped with air-sprung adjustable driver seat, additional passenger seat and adjustable steering column. The cab meets EN 474-1 and EN 474-6 requirements that specify permissible levels of in-cab noise, vibration, content of hazardous substances and dust.

Driver's workplace meets ROPS safety requirements.

In-cab noise level is not more than 80 dB(A).

Local vibration level is not more than 126 dB(A).

Overall vibration level is not more than 115 dB(A).

## Tires

Tubeless air tires with quarry tread pattern.

Tire designation	24.00R35 (E-4)
Inflation pressure, MPa	0,65
Rim designation	17.00-35/3.5

## Overall dimensions, mm\*

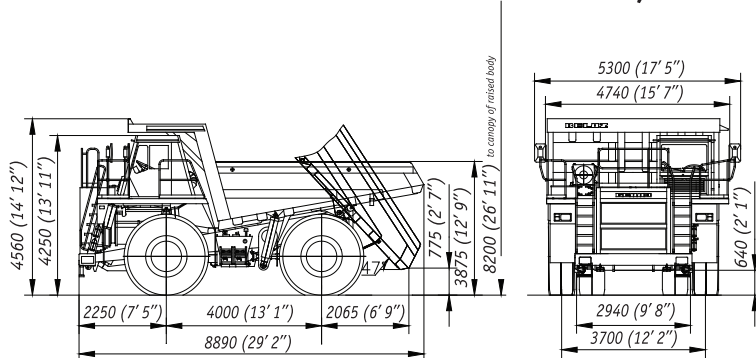

\*Overall dimensions are specified for basic kitting-up of the dump truck

\*\*Excepting dump trucks of tropicalized design

## Weight

Maximum payload capacity, kg	60000	
Unladen weight, kg	44100	
Gross weight, kg	104100	
Dump truck weight distribution on axles, %:		
front	unladen 51,0	laden 33,0
rear	49,0	67,0

## Capacities, l

Fuel tank	740
Engine cooling system	205
Engine lubrication system	60,6
Hydromechanical transmission	90
Hydraulic system	230
Rear axle	108
Suspension cylinders:	
front	30 (15x2)
rear	31,7 (15,85x2)

## Special equipment

Combined fire-fighting system with remote actuation (standard)

Starting preheater (standard)\*\*

Centralized lubrication system (standard)

Heating and conditioning unit (standard)

Fuel and loading control system (standard)

Video observation system (standard)

Telemetering tire pressure control system (standard)

High-voltage line attention device (standard)

Fettling of body floor (option)

## Propulsion and Retarding

### Propulsion performance

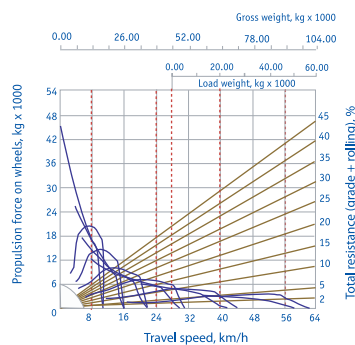

### Retarding performance

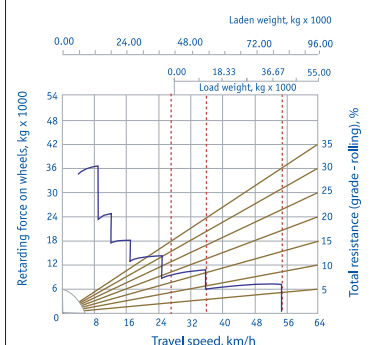

# BELAZ

**OJSC "BELAZ" — Management Company of Holding "BELAZ-HOLDING"**  
 40 let Oktyabrya str. 4, 222160, Zhodino, Minsk region, Republic of Belarus  
 phone: +375 1775 3-27-82, 3-26-23, 3-37-37, fax: +375 1775 7-01-37  
 e-mail: office@belaz.minsk.by, marketing@belaz.minsk.by,  
 export@belaz.minsk.by  
[www.belaz.by](http://www.belaz.by)