

Mine dump truck BELAZ-7547 of payload capacity 45 tonnes (50 short tons)

It's designed for transportation of rock mass in difficult mining and technical conditions of deep mines, at mineral deposit open pits on technological roads under various climatic operating conditions (at ambient temperature from -50 to +50 °C).



Engine

Model	YaMZ-240HM2
Four-cycle turbocharged direct diesel engine with V-type arrangement of cylinders.	
Rated power @ 2100 rpm, kW (hp)	368 (500)
Maximum torque @ 1600 rpm, N.m	1815
Number of cylinders	12
Cylinders displacement, l	22,3
Cylinder diameter, mm	130
Piston stroke, mm	140
Specific fuel consumption at rated power, g/kW hr	224
Air cleaning is performed by three-stage filter with dry-type elements.	
Engine exhaust expulsion is performed through body.	
Mixed-type lubrication system is designed with "wet" crankcase.	
Fluid cooling system with forced circulation.	
Oil cooling is performed by oil-to-water heat exchanger.	
Pneumatic starter starting system.	
Electric equipment system voltage, V	24

Hydromechanical transmission

Hydromechanical transmission with three-shaft matching reduction gear, complex one-stage four-wheeled torque converter with hydraulic clutch mode and automatic locking, four-shaft gearbox with friction clutches and electrohydraulic actuator of gear change control, hydrodynamic blade-type retarder.

Maximum dump truck travel speed, km/h	50	
Ratio of matching reduction gear	1,0	
Ratios of gearbox:		
gears	forward	reverse
1	3,84	6,07
2	2,27	1,67
3	1,50	
4	1,055	
5	0,625	

Suspension

Suspension is conventional for front and driving axles and equipped with longitudinal and transverse rods. Cylinders are pneumohydraulic (nitrogen and oil) with inbuilt hydraulic shock absorber. Two cylinders are on the front axle and four cylinders are on the rear axle.

Cylinder piston stroke, mm	
- front	265
- rear	265

Steering

Hydrostatic steering with steerable front wheels.

Steering angle, degree	35
Turning radius, m	10,2
Overall turning diameter, m	23
The steering meets ISO 5010 requirements.	

Brakes

Dump truck brake system meets ISO 3450 international safety requirements and is equipped with service, parking, auxiliary and emergency brake systems.

Service brake system consists of shoe-drum brake gears for front and rear wheels with pneumatic actuator separated for front and rear wheels.

Parking brake system is permanently closed shoe brake gear on final drive driving shaft with spring actuator and pneumatic control.

Auxiliary brake system is hydrodynamic retarder on gearbox driving shaft with electric control.

Emergency brake system uses parking brake and operable circuit of service brakes.

Hydraulic drive

Hydraulic system is combined for body dumping gear and steering. The system is equipped with gear-type oil pumps, four-stage telescopic body lifting cylinders with one stage of double action.

Body lifting time, s	25
Body lowering time, s	20
Maximum pressure in hydraulic system, MPa	13,5
Maximum pump delivery @ 2100 rpm, dm ³ /min	260
Filtration degree, mcm	10

Body

Welded bucket-type body with FOPS safety system, protective canopy, engine exhaust heating, device for mechanical fixing in raised position, rock-fenders and rock-ejectors.

Body capacity, m³:

struck	heaped 2:1
21,5	27,6
27,4	31,7 (optional)
28,5	33,9 (optional)
35,9	43,3 (optional)

Frame

High-strength low-alloy steel welded frame is equipped with box-section variable-height side-members interconnected by cross-members.



Driving axle

Mechanical driving axle is equipped with single-stage bevel final drive, bevel differential with four pinions and planetary hub drives with spur pinions.

Ratios:

final drive	3,417
hub drive	6,0
driving axle total	20,50

Driveline

Driveline consists of two open-type cardan shafts with joints on needle bearings that join hydromechanical transmission to engine and driving axle. Flexible coupling is mounted between front cardan shaft and engine. Front cardan shaft is equipped with protective guard.

Cab

One-man cab is equipped with air-sprung adjustable driver seat and additional side seat. The cab meets EN 474-1 and EN 474-6 requirements that specify permissible levels of in-cab noise, vibration, content of hazardous substances and dust. Driver's workplace meets ROPS safety requirements.

In-cab noise level is not more than 80 dB(A).

Local vibration level is not more than 126 dB(A).

Overall vibration level is not more than 115 dB(A).

Tires

Air tires with quarry tread pattern.

Tire designation

21.00-35 HC 36 (E-4)

Inflation pressure, MPa

0,575

Rim designation

15.00-35/3.0

Overall dimensions, mm*

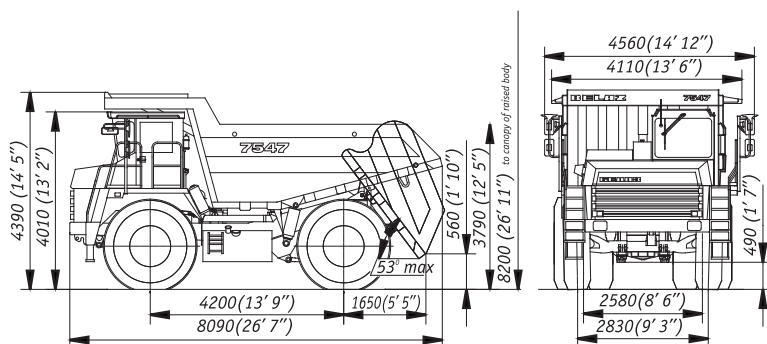

*Overall dimensions are specified for dump truck with standard options

**Excepting dump trucks of tropicalized design

Weight

Maximum payload capacity, kg	45000
Unladen weight, kg	33100
Gross weight, kg	78100
Dump truck weight distribution on axles, %:	
- front	unladen 45,0 / laden 33,0
- rear	unladen 55,0 / laden 67,0

Capacities, l

Fuel tank	610
Engine cooling system	135
Engine lubrication system	54
Hydromechanical transmission	70
Hydraulic system	160
Final drive	24
Hub drives	24 (12x2)
Suspension cylinders	24 (4x6)

Special equipment

Fire-fighting system with remote actuation (standard)

Starting preheater (standard)**

Centralized lubrication system (standard)

High-voltage line attention device (standard)

Conditioner (option)

Auxiliary heater (option)

Electric-heated mirrors (optional)

Propulsion and Retarding

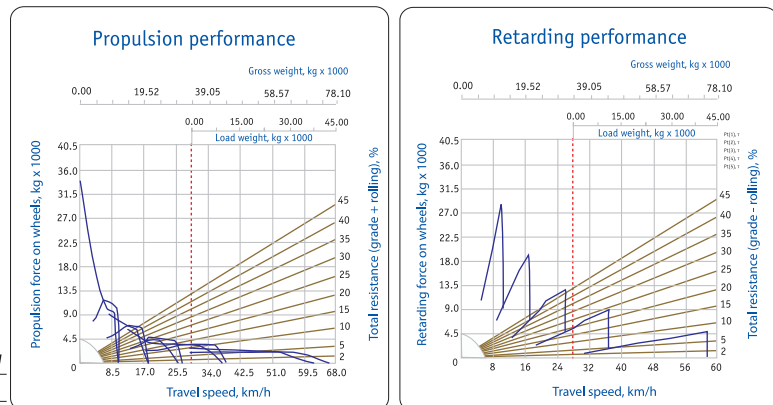

BELAZ

OJSC "BELAZ" — Management Company of Holding "BELAZ-HOLDING"

40 let Oktyabrya str. 4, 222160, Zhodino, Minsk region, Republic of Belarus

phone: +375 1775 3-27-82, 3-26-23, 3-37-37, fax: +375 1775 7-01-37

e-mail: office@belaz.minsk.by, marketing@belaz.minsk.by,

export@belaz.minsk.by

www.belaz.by